

## LWO-QSFP28-LR1

# 100Gbit QSFP28 LR1, 10km, Single Lambda, LC-Duplex, Singlemode

### Features

- QSFP28 MSA compliant
- Supports 53.125Gbaud
- 100G Lambda MSA 100G-LR Specification compliant
- Up to 10km transmission on single mode fiber (SMF) with FEC
- Operating case temperature: 0 to 70°C
- 4x25G electrical interface (OIF CEI-28G-VSR)
- Maximum power consumption 4W
- LC duplex connector
- RoHS compliant

### Application

- Data Center Interconnect
- 100G Ethernet
- Enterprise networking

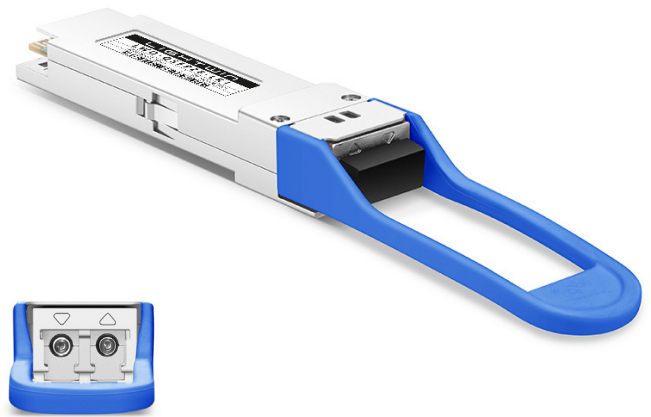

### General Description

This product is a transceiver module designed for 10km optical communication applications. The module incorporates one channel optical signal, on 1310nm center wavelength, operating at 50Gbaud data rate. The transmitter path incorporates an EML Driver integrated in the DSP and a cooled EML together. On the receiver path, the input optical signal is coupled to a Pin photodiode detector. A DSP based gearbox is used to convert 4x25Gbps NRZ signals to 1x50Gbaud PAM4 signal. Also a 4-channel retimer and FEC block are integrated in this DSP. The electrical interface is compliant with IEEE 802.3cd and QSFP28 MSA in the transmitting and receiving directions, and optical interface is compliant to IEEE 802.3cd and 100G Lambda MSA with Duplex LC connector. The module has a maximum power consumption of 4.0W.

The product is designed with form factor, optical/electrical connection and digital diagnostic interface according to the QSFP28 Multi-Source Agreement (MSA). It has been designed to meet the harshest external operating conditions including temperature, humidity and EMI interference.

### Functional Description

This product converts the parallel electrical input signals into a channel optical signal(light) .The transmitter path incorporates modulator drivers integrated in the DSP together with integrated modulators in the SIP PIC . The light propagates out of the transmitter into an SMF fiber. The receiver module accepts the 50Gbaud PAM4 optical signal input, and converts it into a 50Gbaud PAM4 electrical signal via a linear amplifier. And then convert the 50Gbaud PAM4 signal into 4 channels of 25Gbps NRZ signals. Figure 1 shows the functional block diagram of this product.

A single +3.3V power supply is required to power up this product. Both power supply pins VccTx and VccRx are internally connected and should be applied concurrently. As per MSA specifications the module offers seven low speed hardware control pins (including the 2-wire serial interface): ModSelL, SCL, SDA, ResetL, LPMMode, ModPrsL and IntL.

Module Select (ModSelL) is an input pin. When held low by the host, this product responds to 2-wire serial communication commands. The ModSelL allows the use of this product on a single 2-wire interface bus – individual ModSelL lines must be used.

Serial Clock (SCL) and Serial Data (SDA) are required for the 2-wire serial bus communication interface and enable the host to access the memory map.

The ResetL pin enables a complete reset, returning the settings to their default state, when a low level on the ResetL pin is held for longer than the minimum pulse length. During the execution of a reset the host shall disregard all status bits until it indicates a completion of the reset interrupt. The product indicates this by posting an IntL (Interrupt) signal with the Data\_Not\_Ready bit negated in the memory map. Note that on power up (including hot insertion) the module should post this completion of reset interrupt without requiring a reset.

Low Power Mode (LPMMode) pin is used to set the maximum power consumption for the product in order to protect hosts that are not capable of cooling higher power modules, should such modules be accidentally inserted.

Module Present (ModPrsL) is a signal local to the host board which, in the absence of a product, is normally pulled up to the host Vcc. When the product is inserted into the connector, it completes the path to ground through a resistor on the host board and asserts the signal. ModPrsL then indicates its present by setting ModPrsL to a "Low" state.

Interrupt (IntL) is an output pin. "Low" indicates a possible operational fault or a status critical to the host system. The host identifies the source of the interrupt using the 2-wire serial interface. The IntL pin is an open collector output and must be pulled to the Host Vcc voltage on the Host board.

## LWO-QSFP28-LR1

100Gbit QSFP28 LR1, 10km, Single Lambda, LC-Duplex, Singlemode

### Functional Description

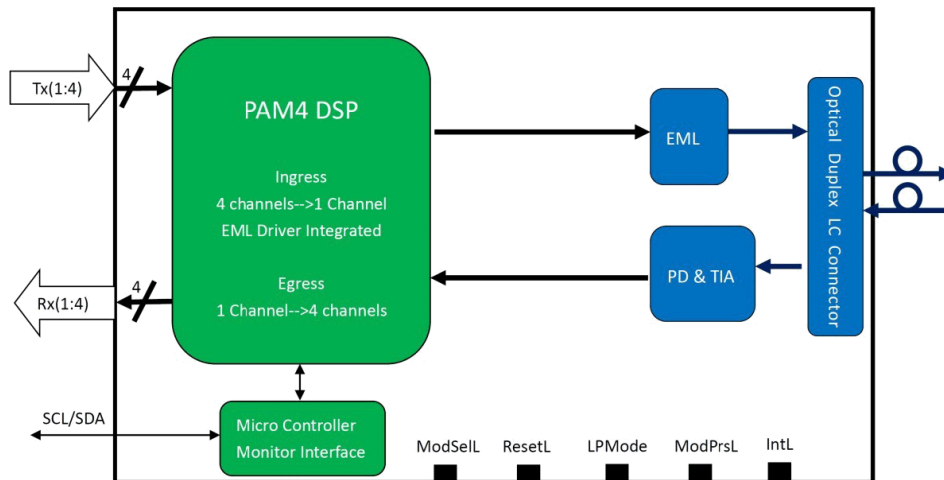

Figure 1. Transceiver Block Diagram

### Pin Assignment and Description



Figure 2. MSA Compliant Connector

## LWO-QSFP28-LR1

### 100Gbit QSFP28 LR1, 10km, Single Lambda, LC-Duplex, Singlemode

#### PIN Definition 1/2

PIN	Logic	Symbol	Name/Description	Notes
1		GND	Ground	1
2	CML-I	Tx2n	Transmitter Inverted Data Input	
3	CML-I	Tx2p	Transmitter Non-Inverted Data Input	
4		GND	Ground	1
5	CML-I	Tx4n	Transmitter Inverted Data Input	
6	CML-I	Tx4p	Transmitter Non-Inverted Data Output	
7		GND	Ground	1
8	LVTTL-I	ModSelL	Module Select	
9	LVTTL-I	ResetL	Module Reset	
10		VccRx	+3.3V Power Supply Receiver	2
11	LVCMOS-I/O	SCL	2-Wire Serial Interface Clock	
12	LVCMOS-I/O	SDA	2-Wire Serial Interface Data	
13		GND	Ground	1
14	CML-O	Rx3p	Receiver Non-Inverted Data Output	
15	CML-O	Rx3n	Receiver Inverted Data Output	
16		GND	Ground	1
17	CML-O	Rx1p	Receiver Non-Inverted Data Output	
18	CML-O	Rx1n	Receiver Inverted Data Output	
19		GND	Ground	1
20		GND	Ground	1
21	CML-O	Rx2n	Receiver Inverted Data Output	
22	CML-O	Rx2p	Receiver Non-Inverted Data Output	
23		GND	Ground	1
24	CML-O	Rx4n	Receiver Inverted Data Output	1
25	CML-O	Rx4p	Receiver Non-Inverted Data Output	
26		GND	Ground	1
27	LVTTL-O	ModPrsL	Module Present	
28	LVTTL-O	IntL	Interrupt	
29		VccTx	+3.3 V Power Supply transmitter	2
30		Vcc1	+3.3 V Power Supply	2
31	LVTTL-I	LPMODE	Low Power Mode	
32		GND	Ground	1
33	CML-I	Tx3p	Transmitter Non-Inverted Data Input	
34	CML-I	Tx3n	Transmitter Inverted Data Output	
35		GND	Ground	1
36	CML-I	Tx1p	Transmitter Non-Inverted Data Input	
37	CML-I	Tx1n	Transmitter Inverted Data Output	
38		GND	Ground	1

## LWO-QSFP28-LR1

### 100Gbit QSFP28 LR1, 10km, Single Lambda, LC-Duplex, Singlemode

#### PIN Definition 2/2

#### Notes

1. GND is the symbol for signal and supply (power) common for QSFP28 modules. All are common within the QSFP28 module and all module voltages are referenced to this potential unless otherwise noted. Connect these directly to the host board signal common ground plane.
2. VccRx, Vcc1 and VccTx are the receiver and transmitter power suppliers and shall be applied concurrently. Recommended host board power supply filtering is shown in Figure 4 below. Vcc Rx, Vcc1 and Vcc Tx may be internally connected within the QSFP28 transceiver module in any combination. The connector pins are each rated for a maximum current of 1000mA.

#### Recommended Power Supply Filter

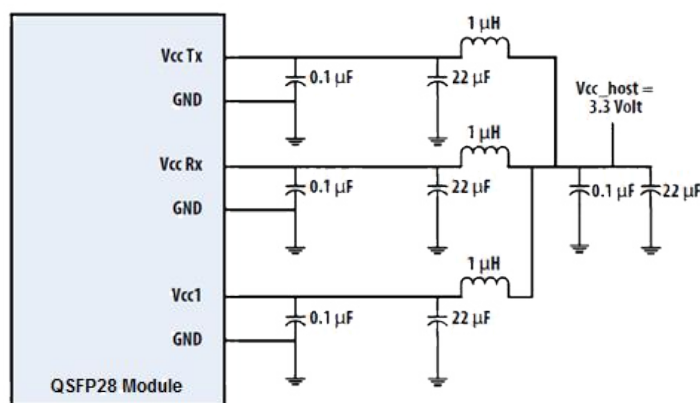

Figure 3. Recommended Power Supply Filter

#### Absolute Maximum Ratings

It has to be noted that the operation in excess of any individual absolute maximum ratings

Parameter	Symbol	Min.	Max.	Units	Notes
Storage Temperature	$T_s$	-40	85	degC	
Operating Case Temperature	$T_{OP}$	0	70	degC	
Power Supply Voltage	$V_{CC}$	-0.5	3.6	V	
Relative Humidity (non-condensation)	RH	0	85	%	
Damage Threshold	$TH_d$	5.5		dBm	

#### Recommended Operating Conditions and Power Supply Requirements

Parameter	Symbol	Min.	Typical	Max.	Units	Notes
Operating Case Temperature	$T_{OP}$	0		70	degC	
Power Supply Voltage	$V_{CC}$	3.135	3.3	3.465	V	
Electrical Data Rate, each Lane (NRZ)			25.78125		Gb/s	
Optical Data Rate (PAM4)			53.125		GBd	
Data Rate Accuracy		-100		100	ppm	
Pre-FEC Bit Error Ratio				$2.4 \cdot 10^{-4}$		
Post-FEC Bit Error Ratio				$1 \cdot 10^{-12}$		1
Control Input Voltage High		2		$V_{CC}$	V	
Control Input Voltage Low		0		0.8	V	
Link Distance with G.652	D	0.002		10000	m	2

#### Notes

1. FEC feature is embedded in the module.
2. FEC required to be turned on to support maximum transmission distance.

## LWO-QSFP28-LR1

### 100Gbit QSFP28 LR1, 10km, Single Lambda, LC-Duplex, Singlemode

#### Electrical Characteristics

The following electrical characteristics are defined over the Recommended Operating Environment unless otherwise specified.

Parameter	Test Point	Min.	Typical	Max.	Units	Notes
Power Consumption				4	W	
Supply Current	I <sub>cc</sub>			1.21	A	
<b>Transceiver (each Lane)</b>						
Overload Differential Voltage pk-pk	TP1a	900			mV	
Common Mode Voltage (Vcm)	TP1	-350		2850	mV	1
Differential Termination Resistance Mismatch	TP1			10	%	At 1MHz
Differential Return Loss (SDD11)	TP1			See CEI-28G-VSR Equation 13-19	dB	
Common Mode to Differential conversion and Differential to Common Mode conversion (SDC11, SCD11)	TP1			See CEI-28G-VSR Equation 13-20	dB	
Stressed Input Test	TP1a	See CEI- 28GVSR Section 13.3.11.2.1				
<b>Receiver (each Lane)</b>						
Differential Voltage, pk-pk	TP4			900	mV	
Common Mode Voltage (Vcm)	TP4	-350		2850	mV	1
Common Mode Noise, RMS	TP4			17.5	mV	
Differential Termination Resistance Mismatch	TP4			10	%	At 1MHz
Differential Return Loss (SDD22)	TP4			See CEI-28G-VSR Equation 13-19	dB	
Common Mode to Differential conversion and Differential to Common Mode conversion (SDC22, SCD22)	TP4			See CEI-28G-VSR Equation 13-21	dB	
Common Mode Return Loss (SCC22)	TP4			-2	dB	2
Transition Time, 20 to 80%	TP4	9.5			ps	
Vertical Eye Closure (VEC)	TP4			5.5	dB	
Eye Width at 10 <sup>-15</sup> probability (EW15)	TP4	0.57			UI	
Eye Height at 10 <sup>-15</sup> probability (EH15)	TP4	228			mV	

#### Notes

- Vcm is generated by the host. Specification includes effects of ground offset voltage.
- From 250MHz to 30GHz.

#### Optical Characteristics 1/2

Parameter	Symbol	Min.	Typical	Max.	Units	Notes
<b>Transceiver</b>						
Center Wavelength	$\lambda_t$	1304.5	1310	1317.5	nm	
Side-mode Suppression Ratio	SMSR	30			dB	
Average Launch Power	P <sub>AVG</sub>	-1.4		4.5	dBm	1
Outer Optical Modulation Amplitude (OMA <sub>outer</sub> )	P <sub>OMA</sub>	-0.7		4.7	dBm	2
Launch Power in OMA <sub>outer</sub> minus TDECQ, each Lane						
for ER ≥ 4.5dB		-0.7			dBm	
for ER < 4.5dB		-0.6				
Transmitter and Dispersion Eye Closure for PAM4	TDECQ			3.4	dB	
TDECQ – 10*log <sup>10</sup> (Ceq)				3.4	dB	3
Extinction Ratio	ER	3.5			dB	

## LWO-QSFP28-LR1

### 100Gbit QSFP28 LR1, 10km, Single Lambda, LC-Duplex, Singlemode

#### Optical Characteristics 2/2

Parameter	Symbol	Min.	Typical	Max.	Units	Notes
RIN <sub>17,1</sub> OMA	RIN			-136	dB/Hz	
Optical Return Loss Tolerance	TOL			15.6	dB	
Transmitter Reflectance	T <sub>R</sub>			-26	dB	
Transmitter Transition Time				17	ps	
Average Launch Power of OFF Transmitter	P <sub>off</sub>			-15	dBm	
<b>Receiver</b>						
Center Wavelength	λ <sub>r</sub>	1304.5	1310	1317.5	nm	
Damage Threshold	TH <sub>d</sub>	5.5			dBm	4
Average Receive Power		-7.7		4.5	dBm	5
Receive Power (OMA <sub>outer</sub> )				4.7	dBm	
Receiver Sensitivity (OMA <sub>outer</sub> )	SEN			Equation (1)	dBm	6
Stressed Receiver Sensitivity (OMA <sub>outer</sub> )	SRS			-4.1	dBm	7
Receiver Reflectance	R <sub>R</sub>			-26	dB	
LOS Assert	LOSA	-15			dBm	
LOS De-assert	LOSD			-10.7	dBm	
LOS Hysteresis	LOSH	0.5			dB	
Stressed Conditions for Stress Receiver Sensitivity						8
Stressed Eye Closure for PAM4 (SECQ)			3.4		dB	
SECQ – 10*log <sup>10</sup> (Ceq)				3.4	dB	

#### Notes 1/2

- Average launch power, each lane (min) is informative and not the principal indicator of signal strength. A transmitter with launch power below this value cannot be compliant; however, a value above this does not ensure compliance.
- Even if the TDECQ < 1.4dB for an extinction ratio of ≥ 4.5dB or TDECQ < 1.3dB for an extinction ratio of < 4.5dB, the OM<sub>Aouter</sub> (min) must exceed the minimum value specified here.
- C<sub>eq</sub> is a coefficient defined in IEEE Std 802.3-2018 clause 121.8.5.3 which accounts for reference equalizer noise enhancement.
- Average receive power, each lane (min) is informative and not the principal indicator of signal strength. A received power below this value cannot be compliant; however, a value above this does not ensure compliance.
- The receiver shall be able to tolerate, without damage, continuous exposure to a modulated optical input signal having this power level on one lane. The receiver does not have to operate correctly at this input power.
- Receiver sensitivity (OMA<sub>outer</sub>), each lane (max) is informative and is defined for a transmitter with a value of SECQ up to 3.4 dB. It should meet Equation (1), which is illustrated in Figure 4.

$$RS = \max(-6.1 \text{ SECQ} - 7.5) \text{ dBm} \quad (1)$$

Where:

RS is the receiver sensitivity, and

SECQ is the SECQ of the transmitter used to measure the receiver sensitivity.

- Measured with conformance test signal at TP3 for the BER equal to 2.4x10<sup>-4</sup>.
- These test conditions are for measuring stressed receiver sensitivity. They are not characteristics of the receiver.

## LWO-QSFP28-LR1

### 100Gbit QSFP28 LR1, 10km, Single Lambda, LC-Duplex, Singlemode

#### Notes 2/2

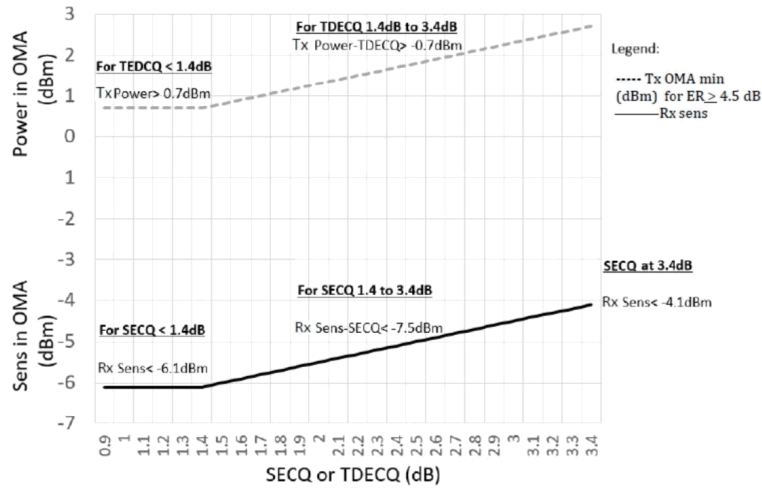

Figure 4. Illustration of Receiver Sensitivity Mask for 100G-LR

#### Mechanical Dimensions

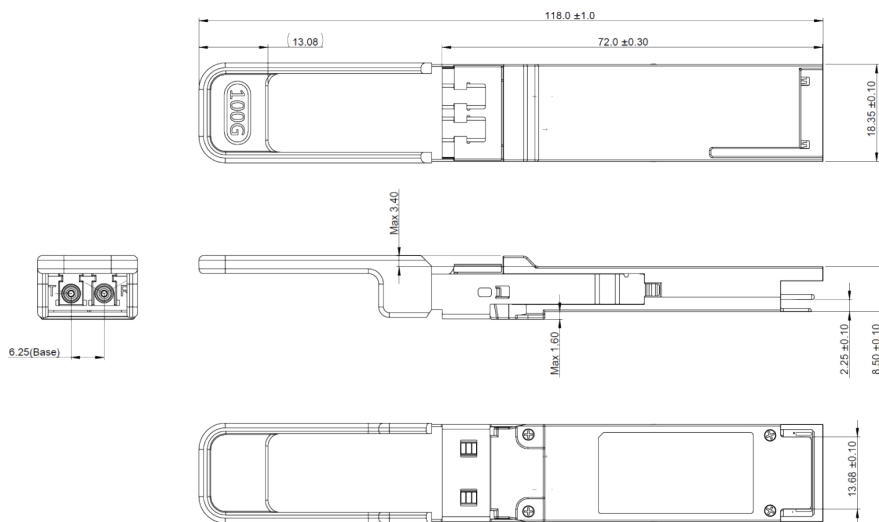

Figure 5. Mechanical Outline

#### ESD

This transceiver is specified as ESD threshold 1kV for high speed data pins and 2kV for all other electrical input pins, tested per MIL-STD-883, Method 3015.4 / JESD22- A114-A (HBM). However, normal ESD precautions are still required during the handling of this module. This transceiver is shipped in ESD protective packaging. It should be removed from the packaging and handled only in an ESD protected environment.

#### Laser Safety

This is a Class 1 Laser Product according to EN 60825-1:2014. This product complies with 21 CFR 1040.10 and 1040.11 except for deviations pursuant to Laser Notice No. 50, dated (June 24, 2007).

Caution: Use of controls or adjustments or performance of procedures other than those specified herein may result in hazardous radiation exposure.

## LWO-QSFP28-LR1

### 100Gbit QSFP28 LR1, 10km, Single Lambda, LC-Duplex, Singlemode

#### Digital Diagnostic Functions

The following digital diagnostic characteristics are defined over the Recommended Operating Environment unless otherwise specified. It is compliant to SFF-8436.

Parameter	Symbol	Min.	Max.	Units	Notes
Temperature monitor absolute error	DMI_Temp	-3	3	degC	Over operating temperature range
Supply voltage monitor absolute error	DMI_VCC	-0.15	0.15	V	Over full operating range
Channel RX power monitor absolute error	DMI_RX_Ch	-2	2	dB	1
Channel Bias current monitor	DMI_Ibias_Ch	-10%	10%	mA	Ch1 ~ Ch4
Channel TX power monitor absolute error	DMI_TX_Ch	-2	2	dB	1

#### Notes

1. Due to measurement accuracy of different single mode fibers, there could be an additional +/-1 dB fluctuation, or a +/- 3 dB total accuracy.