

LWO-QSFP-SR4-BT

40 Gbit QSFP+ SR4, 150m OM3, MTP/MPO-12, Multimode

Features

- Support 40GBASE-SR4/QDR application
- Compliant to QSFP+ Electrical MSA SFF-8436
- Multi rate of up to 10.3125Gbps per lane
- Transmission distance up to 150m (OM3)
- +3.3V single power supply
- Low power consumption
- Operating case temp
- Commercial: 0°C to +70°C
- RoHS compliant

Application

- 40GBASE-SR4 at 10.3125Gbps per lane
- InfiniBand QDR
- Other optical links

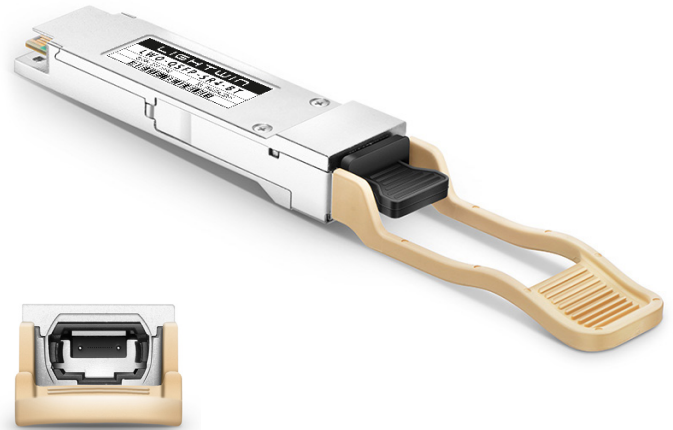

Pin Assignment and Description



Figure 1. MSA Compliant Connector

LWO-QSFP-SR4-BT

40 Gbit QSFP+ SR4, 150m OM3, MTP/MPO-12, Multimode

PIN Definition

PIN	Logic	Symbol	Name/Description	Notes
1		GND	Ground	1
2	CML-I	Tx2n	Transmitter Inverted Data Input	
3	CML-I	Tx2p	Transmitter Non-Inverted Data output	
4		GND	Ground	1
5	CML-I	Tx4n	Transmitter Inverted Data Input	
6	CML-I	Tx4p	Transmitter Non-Inverted Data output	
7		GND	Ground	1
8	LVTTL-I	ModSelL	Module Select	
9	LVTTL-I	ResetL	Module Reset	
10		VccRx	+3.3V Power Supply Receiver	2
11	LVC MOS-I/O	SCL	2-Wire Serial Interface Clock	
12	LVC MOS-I/O	SDA	2-Wire Serial Interface Data	
13		GND	Ground	
14	CML-O	Rx3p	Receiver Non-Inverted Data Output	
15	CML-O	Rx3n	Receiver Inverted Data Output	
16		GND	Ground	1
17	CML-O	Rx1p	Receiver Non-Inverted Data Output	
18	CML-O	Rx1n	Receiver Inverted Data Output	
19		GND	Ground	1
20		GND	Ground	1
21	CML-O	Rx2n	Receiver Inverted Data Output	
22	CML-O	Rx2p	Receiver Non-Inverted Data Output	
23		GND	Ground	1
24	CML-O	Rx4n	Receiver Inverted Data Output	1
25	CML-O	Rx4p	Receiver Non-Inverted Data Output	
26		GND	Ground	1
27	LVTTL-O	ModPrsL	Module Present	
28	LVTTL-O	IntL	Interrupt	
29		VccTx	+3.3 V Power Supply transmitter	2
30		Vcc1	+3.3 V Power Supply	2
31	LVTTL-I	LPMode	Low Power Mode	
32		GND	Ground	1
33	CML-I	Tx3p	Transmitter Non-Inverted Data Input	
34	CML-I	Tx3n	Transmitter Inverted Data Output	
35		GND	Ground	1
36	CML-I	Tx1p	Transmitter Non-Inverted Data Input	
37	CML-I	Tx1n	Transmitter Inverted Data Output	
38		GND	Ground	1

LWO-QSFP-SR4-BT

40 Gbit QSFP+ SR4, 150m OM3, MTP/MPO-12, Multimode

Notes

1. GND is the symbol for signal and supply (power) common for QSFP+ modules. All are common within the QSFP+ module and all module voltages are referenced to this potential unless otherwise noted. Connect these directly to the host board signal common ground plane.
2. VccRx, Vcc1 and VccTx are the receiving and transmission power suppliers and shall be applied concurrently. Recommended host board power supply filtering is shown in Figure 2 below. Vcc Rx, Vcc1 and Vcc Tx may be internally connected within the QSFP+ transceiver module in any combination. The connector pins are each rated for a maximum current of 500mA.

Absolute Maximum Ratings

It has to be noted that the operation in excess of any individual absolute maximum ratings might cause permanent damage to this module.

Parameter	Symbol	Min	Max.	Units	Note
Storage Temperature	T_s	-40	85	degC	
Operating Case Temperature	T_{op}	0	70	degC	
Power Supply Voltage	V_{cc}	-0,5	3.6	V	
Relative Humidity (non- condensation)	RH	0	85	%	
Damage Threshold, each Lane	TH_d	3.4		dbm	

Recommended Operating Conditions and Power Supply Requirements

Parameter	Symbol	Min	Typical	Max.	Units
Operating Case Temperature	T_{OP}	0		70	degC
Power Supply Voltage	V_{CC}	3.135	3.3	3.465	V
Data Rate, each Lane			10.3125	11.2	Gb/s
Power Dissipation	P_d			1.5	E
Link Distance with OM3	D			150	m

Recommended Power Supply Filter

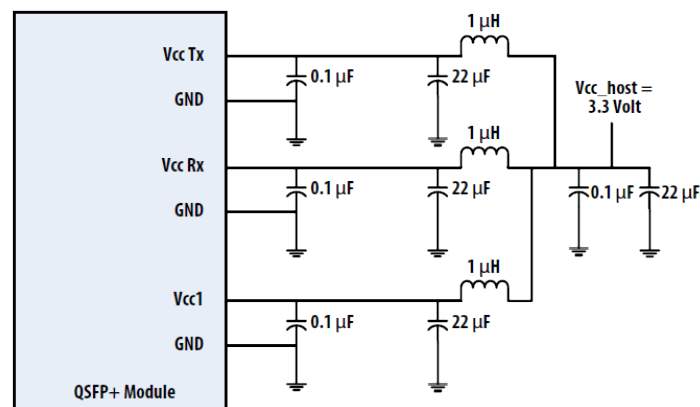

Figure 2. Recommended Power Supply Filter

LWO-QSFP-SR4-BT

40 Gbit QSFP+ SR4, 150m OM3, MTP/MPO-12, Multimode

Electrical Characteristics

The following electrical characteristics are defined over the Recommended Operating Environment unless otherwise specified.

Parameter	Symbol	Min.	Typical	Max.	Units	Notes
Input Logic Level High	V_{IH}	2	-	VCC+0.3	V	
Input Logic Level Low	V_{IL}	$V_{EE}-0.3$	-	0.8	V	
Output Logic Level High	V_{OH}	2	-	VCC+0.3	V	
Output Logic Level Low	V_{OL}	0	-	0.4	V	
Transceiver						
Differential Data Input Swing	$V_{in,P-P}$	200	-	1000	mV _{pp}	
Input Differential Impedance	Z _{IN}	90	100	110	Ω	
Receiver						
Differential Data Output Swing	V_{out}	200	-	1000	mV	
Output Differential Impedance	Z _D	90	100	110	Ω	

Optical Characteristics

The following optical characteristics are defined over the Recommended Operating Environment unless otherwise specified.

Optical Transmitter Characteristics						
Bit Rate	BR	Gbps	1.25	10.3125	-	Per lane
Center Wavelength Range	λ_c	nm	840	850	860	
RMS Spectral Width	$\Delta\lambda$	nm	-	-	0.6	
Average Launch power	P_{off}	dBm	-	-	-30	
Tx_off						
Launch Optical Power	P_0	dBm	-6		2.4	1
Extinction Ratio	ER	dB	3	-	-	
Optical Receiver Characteristics						
Bit Rate	BR	Gbps	1.25	10.3125	-	Per lane
Sensitivity@BER=E-12	BER	dBm	-	-	-10.3	
Overload Input Optical Power	P_{IN}	dBm	2.4	-	-	2
Power						
Center Wavelength Range	λ_c	nm	840	-	860	
LOS Assert	-	dBm	-30	-	-	
LOS De-Assert	-	dBm	-	-	-12	
LOS Hysteresis	-	Db	0.5	-	-	

Notes

- Coupled into 50/125 MMF.
- Measured with PRBS 2³¹-1 test pattern @10.3125Gbps.BER=E-12

LWO-QSFP-SR4-BT

40 Gbit QSFP+ SR4, 150m OM3, MTP/MPO-12, Multimode

Digital Diagnostic Functions

The following digital diagnostic characteristics are defined over the normal operating conditions unless otherwise specified.

Parameter	Symbol	Min.	Max.	Units	Notes
Temperature monitor absolute error	DMI_Temp	-3	3	degC	Over operating temperature range
Supply voltage monitor absolute error	DMI_VCC	-0.1	0.1	V	Over full operating range
Channel RX power monitor absolute error	DMI_RX_Ch	-2	2	dB	1
Channel Bias current monitor	DMI_Ibias_Ch	-10%	10%	mA	
Channel TX power monitor absolute error	DMI_TX_Ch	-2	2	dB	1

Notes

- Due to measurement accuracy of different single mode fibers, there could be an additional +/- 1 dB fluctuation, or a +/- 3 dB total accuracy.

Mechanical Dimensions

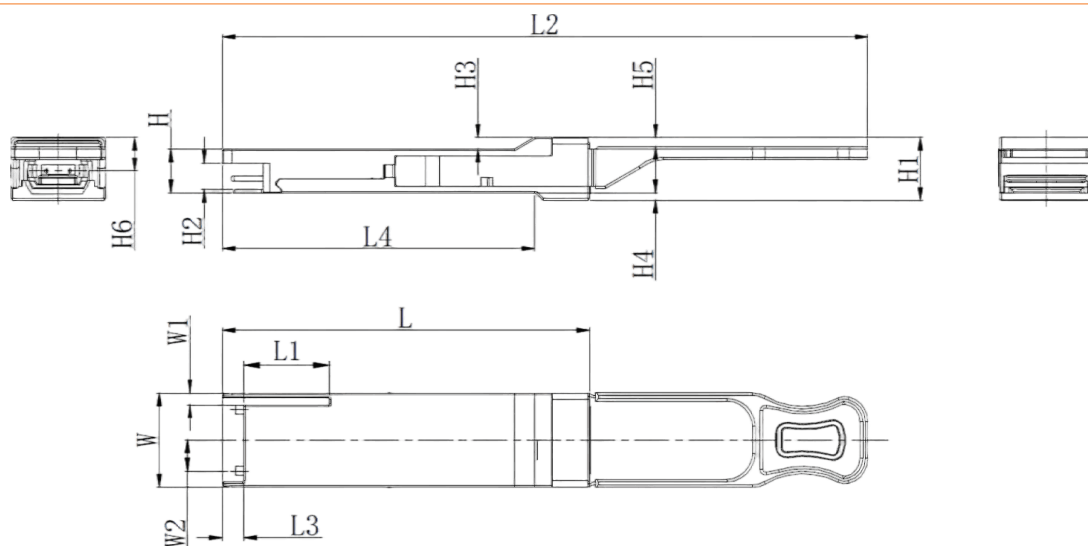

Figure 3. Mechanical Outline

ESD

This transceiver is specified as ESD threshold 1kV for SFI pins and 2kV for all other electrical input pins, tested per MIL-STD-883, Method 3015.4 /JESD22-A114-A (HBM). However, normal ESD precautions are still required during the handling of this module. This transceiver is shipped in ESD protective packaging. It should be removed from the packaging and handled only in an ESD protected environment.

Laser Safety

This is a Class 1 Laser Product according to EN 60825-1:2014. This product complies with 21 CFR 1040.10 and 1040.11 except for deviations pursuant to Laser Notice No. 50, dated (June 24, 2007).

Caution: Use of controls or adjustments or performance of procedures other than those specified herein may result in hazardous radiation exposure.