

LWO-SFP2-RJ45-M

2.5 Gbit SFP, RJ45, 100m

Features

- Support 2.5Gbase-T / 1000base-T/ 100base-T on line port
- Support 2.5Gbase-X on host port
- Hot-pluggable SFP footprint
- Compact RJ-45 connector assembly
- RoHS compliant and lead-free
- Single +3.3V power supply
- 2.5 Gigabit Ethernet over Cat 5E cable
- Ambient Operating temperature: 0°C to +70°C
- Power dissipation <1.5W

Product Description

LWO-SFP2-RJ45-M Copper Small Form Pluggable (SFP) transceivers are based on the SFP Multi Source Agreement (MSA) . They are compatible with the 2.5Gbase-T / 1000base-T/100base-T standards as specified in IEEE Std 802.3.

LWO-SFP2-RJ45-M uses the SFP's RX_LOS (must be pulled up on host) pin for link indication. If pull up or open SFP's TX_DISABLE pin, PHY IC be reset.

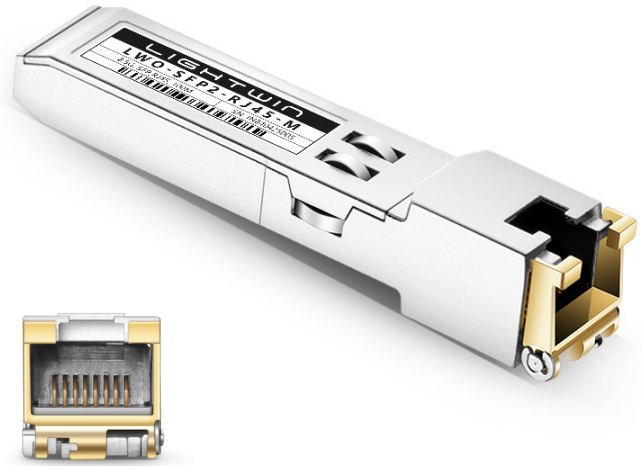

Cable Length

Line Port	Host Port	Cable	Reach
2.5Gbase-T	2.5Gbase-X	CAT5E	100m
1000base-T	2.5Gbase-X	CAT5E	100m
100base-T	2.5Gbase-X	CAT5E	100m

In the ingress direction, the entire packet is fully buffered prior to being transmitted out of Host port at 2.5Gbps. In the egress direction, the 2.5Gbps packet is buffered since the line port at a slow speed, the egress packet should be throttled to match the lower speed by extending the IPG between packet. flow control can be enabled on the host side MAC to limit the flow of packets.

SFP to Host Connector Pin Out

Pin	Symbol	Name/Description	Ref.
1	VEET	Transmitter Ground (Common with Receiver Ground)	
2	TFAULT	Transmitter Fault. Not supported.	
3	TxDIS	High: Reset PHY chipset; Low: Normal	1
4	MOD_DEF(2)	Module Definition 2. Data line for Serial ID.	2
5	MOD_DEF(1)	Module Definition 1. Clock line for Serial ID.	2
6	MOD_DEF(0)	Module Definition 0. Grounded within the module.	2
7	Rate Select	No connection required	
8	LOS	High indicates no linked on Copper. low indicates linked on Copper.	
9	VEER	Receiver Ground (Common with Transmitter Ground)	
10	VEER	Receiver Ground (Common with Transmitter Ground)	
11	VEER	Receiver Ground (Common with Transmitter Ground)	
12	RD-	Receiver Inverted DATA out. AC Coupled	
13	RD+	Receiver Non-inverted DATA out. AC Coupled	
14	VEER	Receiver Ground (Common with Transmitter Ground)	
15	VCCR	Receiver Power Supply	
16	VCCT	Transmitter Power Supply	
17	VEET	Transmitter Ground (Common with Receiver Ground)	
18	TD+	Transmitter Non-Inverted DATA in. AC Coupled.	
19	TD-	Transmitter Inverted DATA in. AC Coupled.	
20	VEET	Transmitter Ground (Common with Receiver Ground)	

LWO-SFP2-RJ45-M

2.5 Gbit SFP, RJ45, 100m

Notes

- PHY disabled on $T_{DIS} > 2.0V$ or open, enabled on $T_{DIS} < 0.8V$
- Should be pulled up with 4.7k - 10k Ohms on host board to a voltage between 2.0 V and 3.6 V. MOD_DEF(0) pulls line low to indicate module is plugged in

Diagram of Host Board Connector Block Pin Numbers and Names

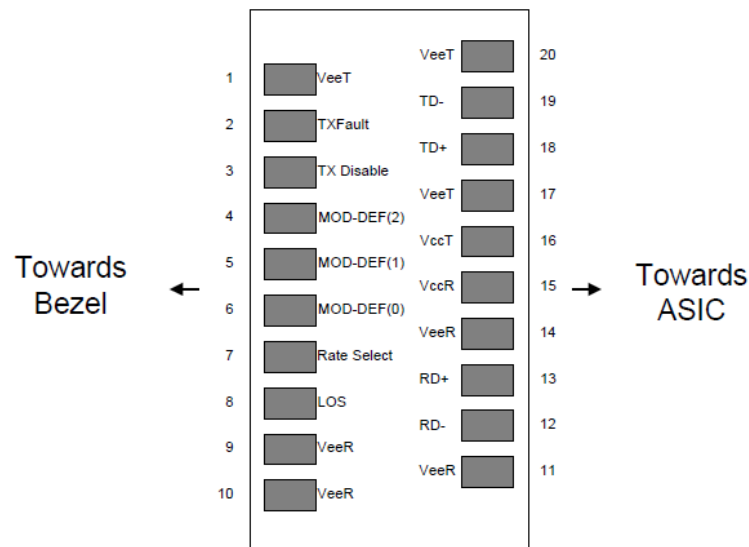

+3.3V Volt Electrical Power Interface

The LWO-SFP2-RJ45-M has an input voltage range of 3.3 V +/- 5%. The 4V maximum voltage is not allowed for continuous operation. Caution: Power consumption and surge current are higher than the specified values in the SFP MSA

Parameter	Symbol	Min	Typ	Max	unit	Notes/Conditions
Supply Current	Icc			450	mA	
Input Voltage	Vcc	3.13	3.3	3.47	V	Referenced to GND
Maximum Voltage	Vmax			4	V	

Low-Speed Signals

MOD_DEF(1) (SCL) and MOD_DEF(2) (SDA), are open drain CMOS signals (see section VII, „Serial Communication Protocol“). Both MOD_DEF(1) and MOD_DEF(2) must be pulled up to host_Vcc

Parameter	Symbol	Min	Max	Unit	Notes/Conditions
SFP Output LOW	VOL	0	0.5	V	4.7k to 10k pull-up to host_Vcc, measured at host side of connector
SFP Output HIGH	VOH	host_Vcc - 0.5	host_Vcc + 0.3	V	4.7k to 10k pull-up to host_Vcc, measured at host side of connector
SFP Input LOW	VIL	0	0.8	V	4.7k to 10k pull-up to Vcc, measured at SFP side of connector
SFP Input HIGH	VIH	2	Vcc + 0.3	V	4.7k to 10k pull-up to Vcc, measured at SFP side of connector

LWO-SFP2-RJ45-M

2.5 Gbit SFP, RJ45, 100m

High-Speed Electrical Interface

All high-speed signals are AC-coupled internally.

High-Speed Electrical Interface, Transmission Line-SFP

Parameter	Symbol	Min	Typ	Max	Unit	Notes/Conditions
Tx Output Impedance	Zout,TX		100		Ohm	Differential, for all frequencies between 1MHz and 125MHz
Rx Input Impedance	Zin,RX		100		Ohm	Differential, for all frequencies between 1MHz and 125MHz

High-Speed Electrical Interface, Host-SFP

Parameter	Symbol	Min	Typ	Max	Unit	Notes/Conditions
Differential data input swing	Vinsing	125		750	mV	Single ended
Differential data output swing	Voutsing	400		750	mV	Single ended
Rise/Fall Time	Tr,Tf	30			psec	20% - 80%
Tx Input Impedance	Zin		100		Ohm	Differential
Rx Output Impedance	Zout		100		Ohm	Differential

General Specifications

General

Parameter	Symbol	Min	Typ	Max	Unit	Notes/Conditions
Data Rate	BR	1		2.5	Gb/sec	IEEE 802.3 compatible. See Notes 1,2 below

Notes

1. Clock tolerance is +/- 50 ppm

Environmental Specifications

Automatic crossover detection is enabled. External crossover cable is not required

Parameter	Symbol	Min	Typ	Max	Unit	Notes/Conditions
Operating Temperature	Top	0		70	°C	Case temperature
Storage Temperature	Tsto	-40		85	°C	Ambient temperature

Serial Communication Protocol

All LIGHTWIN SFPs support the 2-wire serial communication protocol outlined in the SFP MSA. These SFPs use an MCU, can be accessed with address of A0h and A2h.

Serial Bus Timing, Requirements

Parameter	Symbol	Min	Typ	Max	Unit	Notes/Conditions
I ² C Clock Rate		0		200,000	Hz	

LWO-SFP2-RJ45-M

2.5 Gbit SFP, RJ45, 100m

EEPROM INFORMATION (A0)

Addr	Field Size (Bytes)	Name of Field	HEX	Description
0	1	Identifier	03	SFP
1	1	Ext. Identifier	04	MOD4
2	1	Connector	07	LC
3-10	8	Transceiver	00 01 00 00 00 00 00 00	Transmitter Code
11	1	Encoding	05	SONET SCRAMBLED
12	1	BR, nominal	19	2500M bps
13	1	Reserved	00	
14	1	Length (9um)-km	00	
15	1	Length (9um)	00	
16	1	Length (50um)	1E	300
17	1	Length (62.5um)	14	200
18	1	Length (copper)	00	
19	1	Reserved	00	
20-35	16	Vendor name	57 49 4E 54 4F 50 20 20 20 20 20 20 20 20 20 20	LIGHTWIN
36	1	Reserved	00	
37-39	3	Vendor OUI	00 00 00	49
40-55	16	Vendor PN	xx xx xx xx xx xx xx xx xx xx xx xx xx xx xx xx	ASC II
56-59	4	Vendor rev	31 2E 30 20	V1.0
60-61	2	Wavelength	03 52	850nm
62	1	Reserved	00	
63	1	CC BASE	XX	Check sum of byte 0~62
64-65	2	Options	00 1A	LOS, TX_DISABLE, TX_FAULT
66	1	BR, max	00	
67	1	BR, min	00	
68-83	16	Vendor SN	00 00 00 00 00 00 00 00 00 00 00 00 00 00 00 00	Unspecified
84-91	8	Vendor date code	XX XX XX 20	Year, Month, Day
92-94	3	Reserved	00	
95	1	CC_EXT	XX	Check sum of byte 64~94
96-255	160	Vendor specific		

LWO-SFP2-RJ45-M 2.5 Gbit SFP, RJ45, 100m

Recommended Application Circuit

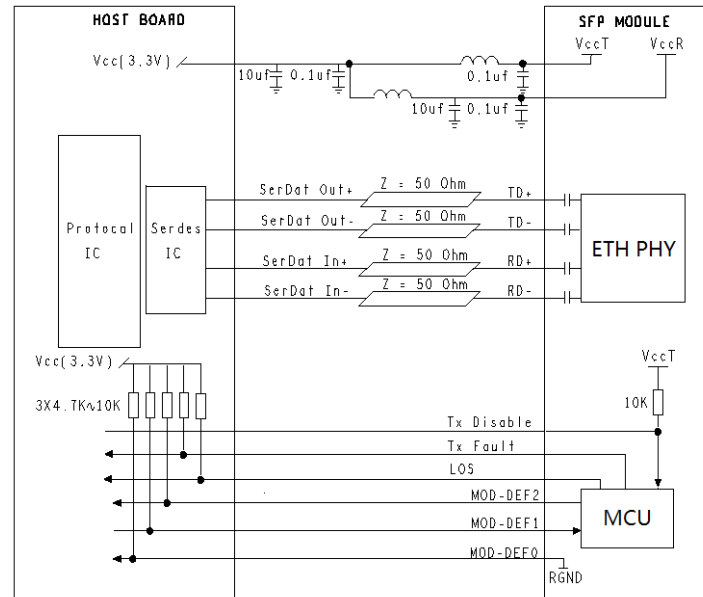

Outline Dimensions (mm)

